



INSTRUCTIONS FOR USE

CURIS® flow Irrigation pump





















REF 350950

Read carefully before use
and retain for future reference!

Table of contents

1	EXPLANATION OF SYMBOLS AND ABBREVIATIONS	1
2	SYSTEM DESCRIPTION.....	3
2.1	Function and meaning of the display and control elements.....	3
2.2	Intended use	5
2.2.1	Purpose	5
2.2.2	Contraindications	5
2.2.3	Side effects.....	5
2.2.4	Essential performance characteristics	5
3	COMMISSIONING	5
3.1	Setup for use with the CURIS® RF Generator	6
3.2	Setup for use with the corresponding footswitch	6
3.3	Potential equalization connection	6
3.4	Mains connection.....	6
3.5	System start and self-test.....	7
3.6	Inserting the bipolar cord and tubing set	7
4	OPERATION	9
4.1	Additional operating functions	10
4.2	Decommissioning.....	11
5	SAFETY MEASURES AND PRECAUTIONS	11
6	CLEANING AND DISINFECTION.....	12
7	ERROR DISPLAY AND TROUBLESHOOTING	12
7.1	Maintenance and repair	15
8	ACCESSORIES.....	15
9	TRANSPORTATION AND PACKAGING	16
9.1	Incoming inspection and transport damage	17
9.2	Claims for damages	17
9.3	Returns	17
9.4	Device disposal	17
10	TECHNICAL INFORMATION.....	18
10.1	Technical data, standards, certification	18
10.2	Guidelines and manufacturer declaration for electromagnetic compatibility	18
10.2.1	Electromagnetic emissions.....	19
10.2.2	Electromagnetic interference resistance.....	19

1 Explanation of symbols and abbreviations

	Warning, attention
	Note
	Temperature limit
	Relative humidity limit
	Air pressure limit
	Medical device
	Compliant with Regulation 2017/745/EU (MDR)
Rx ONLY	Sale restricted to attending physicians (USA)
	Disposal notice (WEEE symbol)
	Manufacturer
	Manufacturing date
	Catalog number
	Serial number
	Observe the instructions for use
 / PA	Potential equalization
 / CF	Type CF applied part (Cardiac Floating)
E	Error (fault indication or error message)
	This side up
	Protect against moisture
	Caution, fragile
IP21	Protection class (IP class)
°C	Degrees Celsius
%	Percent
∅	Diameter

AC	Alternating current
A/m	Ampere/meter
cm	Centimeter
dB(A)	Assessed sound pressure level
EMC	Electromagnetic compatibility
ESD	Electrostatic discharge
GHz	Gigahertz
hPa	Hectopascal
HF	High frequency
Hz	Hertz
kg	Kilogram
kHz	Kilohertz
kV	Kilovolt
m	Meter
mA	Milliampere
ml	Milliliter
max.	Maximum
MHz	Megahertz
min	Minute
mm	Millimeter
PE	Potential equalization
RF	Radio frequency
V	Volt
VA	Volt-ampere
V _{eff.}	Effective value
V/m	Volt/meter
W	Watts

2 System description

The CURIS® flow is an irrigation pump for the supply of isotonic saline solution to the surgical area with the integrated peristaltic pump, either with an insertable bipolar cord / tubing set together and a bipolar irrigation instrument or with an irrigation tubing. The selected flow setting is displayed on the irrigation pump and can be changed using a control element. It can be used in conjunction with the CURIS® 4 MHz radiofrequency generators from Sutter Medizintechnik GmbH or on its own with a corresponding one-pedal footswitch with push-button, available as an option (see accessories in [Chapter 8](#)).

Scope of delivery:

- 1x CURIS® flow Irrigation pump (REF: 350950)
- 1x US mains cable (REF: 93001047)
- 1x EU mains cable (REF: 93006957)
- 1x CURIS® RF Generator interconnecting cable (REF: 93008120)
- 1x Instructions for use (REF: 899080-XX)
- 1x CURIS® flow IV pole mounting bracket (REF: 360901)

2.1 Function and meaning of the display and control elements

Front of the device:



- 1 Power switch**
Turns the irrigation pump on and off
- 2 Display**
Shows the selected flow setting
- 3 Flow setting control element**
Turning clockwise increases, turning counterclockwise decreases the flow rate
- 4 Flush function button**
Pressing the “Flush” button activates the irrigation pump with a predefined, fixed flow setting (max. flow rate)
- 5 LED status indicator**
Lights up red and indicates a device defect
- 6 Pause function button**
Pressing the “Pause” button activates pause mode, supply of irrigation fluid is paused and the flow setting on the display starts flashing

- 7 Rotary pump with flow direction indicator**
Pumps the irrigation fluid in the specified flow direction through the inserted bipolar cord / tubing set or irrigation tubing to the surgical area
- 8 Rotary pump lock lever**

Back of the device:

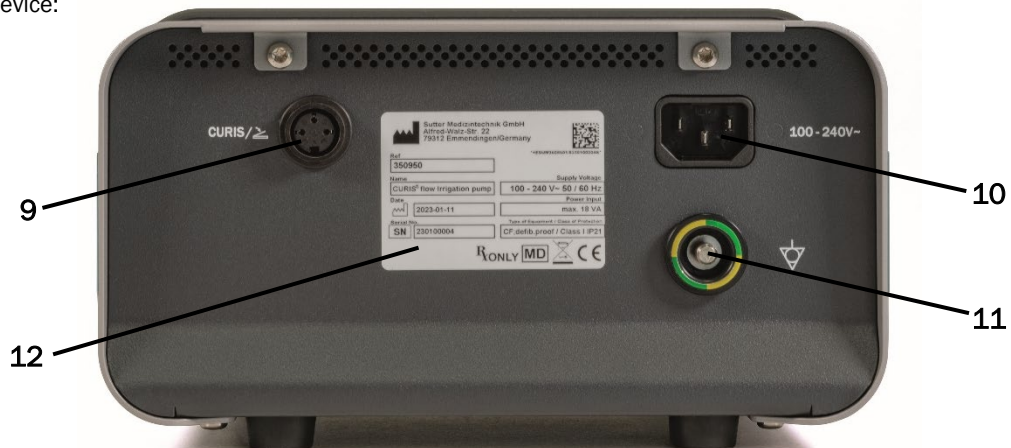

- 9 Connection socket**
For the corresponding CURIS® RF Generator interconnecting cable (REF: 93008120) or the optional CURIS® flow one-pedal footswitch with push-button (REF: 360115)
- 10 Mains cable connection socket**
- 11 PE connection for electric potential equalization**
To establish a potential equalization connection in rooms where potential equalization is required
- 12 Type plate**

Bottom of the device:

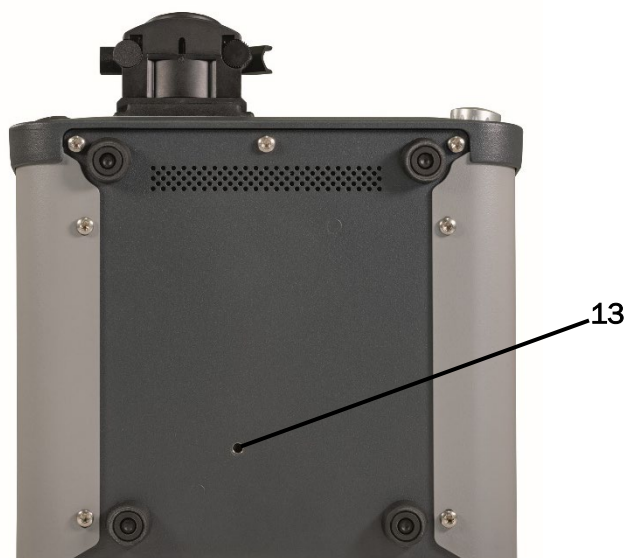

- 13 IV pole mounting bracket connection socket**
For connecting the supplied CURIS® flow IV pole mounting bracket (REF: 360901)

**NOTE**

In the chapters that follow, the numbers in brackets, for example (X), represent the item numbers of the display and control elements in the illustrations of the front and rear of the device.

2.2 Intended use

2.2.1 Purpose

The Sutter irrigation pump is indicated to provide sterile isotonic saline solution for improved procedural site visualization.

2.2.2 Contraindications

No contraindications that apply to the product directly are known at this time. The safety measures described in [Chapter 5](#) have to be observed in addition.

2.2.3 Side effects

No side effects that apply to the product directly are known at this time. To avoid unintended effects, the safety measures described in [Chapter 5](#) have to be observed.

2.2.4 Essential performance characteristics

The Sutter CURIS® flow Irrigation pump has no essential performance characteristics.

3 Commissioning

**NOTE**

To avoid unintentional irrigation, the irrigation pump has to be switched off during setup.

Position the CURIS® flow Irrigation pump on a sturdy, horizontal surface.

Alternatively, the CURIS® flow IV pole mounting bracket (REF: 360901) that is part of the delivery scope can be used to connect the irrigation pump to an IV stand (Ø 15 - 25mm).

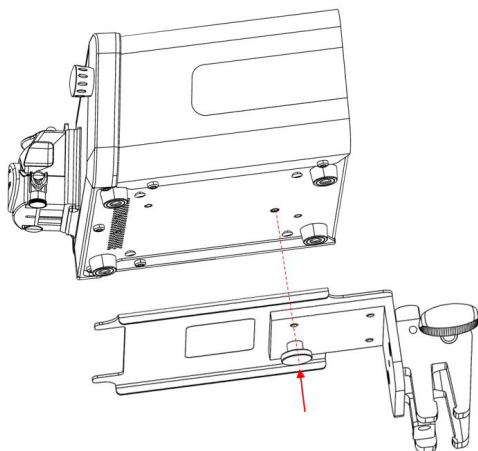

To do so, attach the IV pole mounting bracket to a corresponding IV stand. Then connect the IV pole mounting bracket to the irrigation pump using the connection socket (13) on the bottom of the device. Use the supplied mounting screws for this purpose.

**NOTE**

When the IV pole mounting bracket is mounted on an IV stand, check for tipping resistance and ensure this is maintained at all times.

3.1 Setup for use with the CURIS® RF Generator

CURIS/  Connect either end of the supplied CURIS® RF Generator interconnecting cable (REF: 93008120) to the connection socket (9) on the rear of the irrigation pump.



Connect the other end of the interconnecting cable to the connection socket marked “PUMP” on the rear of the CURIS® RF Generator.

3.2 Setup for use with the corresponding footswitch

CURIS/  Connect the CURIS® flow one-pedal footswitch with push-button, available as an option (REF: 360115), to the connection socket (9) on the rear of the irrigation pump.

3.3 Potential equalization connection

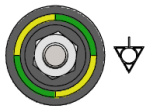

Potential equalization is a connection of device housings with good electrical conductivity. It is intended to ensure that the devices consistently maintain the same electrical potential, even in case of an electrical defect. For optional potential equalization, use the potential equalization connection (11). Push the potential equalization cable on firmly until it snaps into place. The potential equalization cable is not included in the scope of delivery.

3.4 Mains connection



WARNING

To exclude the risk of electric shock, this device may only be connected to a mains network with protective conductor.

The device is equipped with a multi-voltage power supply. It can be operated in the following voltage range without switching:

100 – 240 V AC, 50 / 60 Hz

Connect the mains cable to the connection socket (10) on the rear of the device and connect the other end of the mains cable to an outlet.

For the all-phase, full disconnection of the device in case of danger, either the connection socket on the device or the outlet where the mains cable is plugged in should be left accessible.

No special measures are required to take the device out of operation.



NOTE

Inspect the mains cable and plug for proper function and damage before each use.

3.5 System start and self-test



Turning the device on and off:

The device is turned on and off by using the power switch on the front of the device (1).

When it is switched on, an automatic self-test is performed. The display (2) and LED status indicator (5) light up briefly. When the self-test has successfully completed, the LED status indicator (5) turns off and the last used flow setting is displayed, indicating that the irrigation pump is operational.

An error in the self-test sequence indicates a device defect, the LED status indicator (5) lights up red and the error message “E” is shown on the display. See “Error display and troubleshooting” in [Chapter 7](#).



NOTE

The factory flow setting “0” is shown the first time the device is powered up.

3.6 Inserting the bipolar cord and tubing set



WARNING

Make sure that the CURIS® flow Irrigation pump is turned off while inserting the tubing set. Failure to comply can result in user injury!



NOTE

Sutter recommends using compatible bipolar cord / tubing sets or irrigation tubing. Using other bipolar cord / tubing sets or irrigation tubing may cause deviating fluid volumes (excess or short dosing of the irrigation fluid) and failure of the irrigation pump. The CURIS® flow Irrigation pump can be used with the sterile Bipolar irrigator integrated tubing and cord set (REF: 6790-100-004, 6790-100-003) manufactured by Stryker and the sterile CODMAN® Integrated Bipolar Cord and Tubing sets (REF: 9190001RP, 9190002RP).



NOTE

When using a sterile bipolar cord / tubing set or irrigation tubing, verify that the sterile packaging is intact before use.

Do NOT use the bipolar cord / tubing set or irrigation tubing if:

- The sterile packaging or product is visibly damaged
- The packaging has been opened
- Applied sterility indicators do not have the required color
- The expiration date has been exceeded.

If CURIS® flow Irrigation pump is used as stand-alone device, the following points 8 and 9 are not applicable or required.

1. Use sterile means to remove the bipolar cord / tubing set or irrigation tubing from the packaging and ensure that sterility is maintained while inserting it.
2. Remove the protective cap on the spike of the irrigation tube and pierce the irrigation fluid bag with the spike. Do not twist!
3. Secure the clamp on the irrigation tube.
4. Suspend the irrigation fluid bag on an IV stand with the spike facing down.

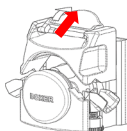

5. Open the lock lever of the rotary pump (8) and grasp the soft silicone segment between the two plastic fitting pieces on the tubing set.

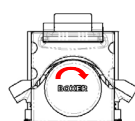

6. Insert the soft silicone segment into the rotary pump (7), making sure that the flow direction matches the direction of flow indicator.



NOTE

The spike of the irrigation tube has to be located on the left side and the luer connection on the right side of the rotary pump (7).

7. Close the lock lever of the rotary pump (8).



WARNING

Make sure that the inserted silicone segment is not pinched while closing the lock lever.

8. Connect the generator plug of the bipolar cord / tubing set to the bipolar connection socket of the CURIS® RF Generator.
9. Connect the bipolar irrigation instrument to the luer connection and instrument socket of the bipolar cord / tubing set.



WARNING

Make sure that the instrument socket connection is fully inserted. Risk of electric shock and possible injury to the user or patient!

10. Priming the tubing set:

Switch on the device with the power switch on the front of the device (1). Release the clamp on the irrigation tubing and then start priming using one of the following two methods (10a or 10b).



- a. Press and hold the “Flush” button (4) until the irrigation fluid flows freely through the irrigation tubing and is as free of visible bubbles as possible.
- b. Turn the flow setting control element (3) clockwise until the flow setting “20” is displayed. Press and hold the foot pedal until the irrigation fluid flows freely through the irrigation tubing and is as free of visible bubbles as possible.

4 Operation

Functionality:

When used with the CURIS® RF Generator, activating a bipolar coagulation mode on the generator (COAG pedal) simultaneously activates the irrigation pump according to the selected flow setting. Pressing the push-button on the footswitch activates the flush function. The connection to the RF generator can be paused via the pause function button (6). See [Chapter 4.1 Additional operating functions](#).

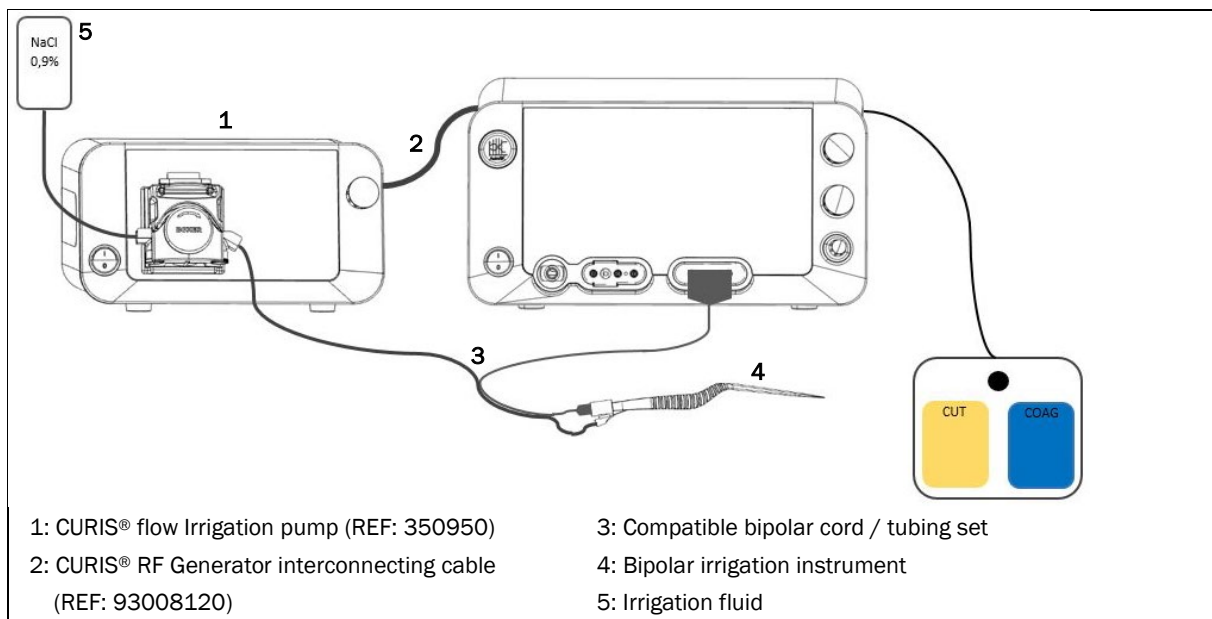

When using the irrigation pump independently with the CURIS® flow one-pedal footswitch with push-button (REF: 360115), the irrigation pump is activated when the footswitch pedal is operated. Pressing the push-button on the footswitch activates the flush function. See [Chapter 4.1 Additional operating functions](#).

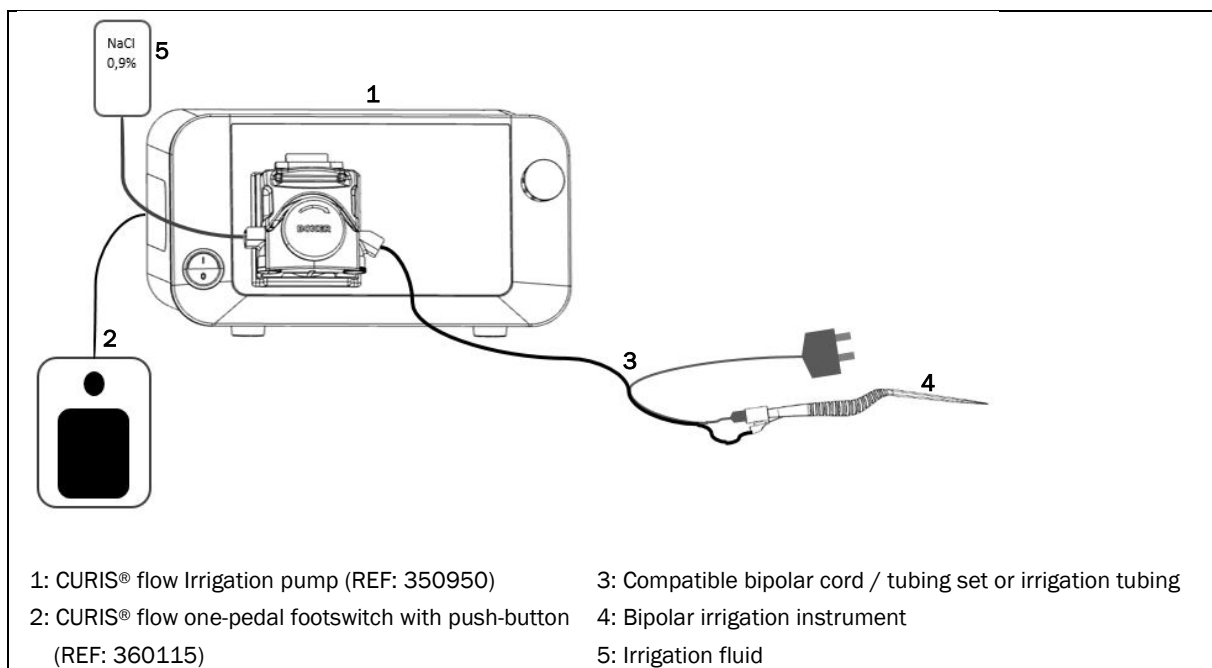

**WARNING**

Prior to operation, make sure that the lock lever of the rotary pump (8) is closed. Failure to comply can cause injury to the user!

The CURIS® flow Irrigation pump offers the possibility to select 20 flow settings from 0 to 20. When the recommended bipolar cord / tubing set or irrigation tubing is used, these correspond to 0 to 20 ml/min.

Check the selected flow setting before each use and adjust if required.

**NOTE**

In principle, select the lowest flow setting for the required irrigation and increase the flow rate if needed.



Turn the control element (3) to select the desired flow rate. The selected flow setting is shown on the display (2).

**NOTE**

The flow setting can be increased by turning the control element (3) clockwise or decreased by turning it counterclockwise. The flow setting can be changed during operation.

To supply irrigation fluid to the surgical area, press and hold the footswitch (blue COAG pedal) connected to the RF generator or the CURIS® flow one-pedal footswitch connected to the irrigation pump. Release to interrupt the supply of irrigation fluid.

**NOTE**

Make sure that sufficient irrigation fluid is available at all times. If needed, change the irrigation fluid bag before it is entirely empty.

4.1 Additional operating functions

The device is equipped with the following additional operating functions.

Flush function

The flush function can be activated with the button (4) on the front of the device or the additional push-button on the footswitch. It activates the irrigation pump with the maximum flow setting. Irrigation fluid is supplied as long as the button (4) or push-button on the footswitch is activated.

The flush function can be used to prime the irrigation tubing, see [chapter 3.6, point 10](#).

Pause function

The pause function can be activated / deactivated with the button (6) on the front of the device. The supply of irrigation fluid is paused and the flow setting on the display starts flashing.

While using the irrigation pump together with the CURIS® RF Generator, the connection is interrupted, and the RF generator can be activated without supplying irrigation fluid.

4.2 Decommissioning



No special measures are required to take the device out of operation. Turn the device off with the power switch on the front of the device (1).

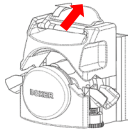

Subsequently, open the lock lever of the rotary pump (8) and remove the inserted tubing set. Then close the lock lever of the rotary pump (8) again.

5 Safety measures and precautions

WARNING



To avoid danger for the patient, operating personnel, or third parties, the device must always be used carefully and strict compliance with the operating and safety instructions is required!



The irrigation pump is intended for operation exclusively by qualified medical personnel.



Verify the correct functioning of the mains and interconnecting cable before each surgical use and replace if needed.



Verify the correct flow direction while inserting the tubing set into the rotary pump! Failure to observe the indicator arrow can cause injury to the patient!



Only use irrigation fluids that met the needs of the medical procedure, and which are suitable for medical use.



Verify the correct functioning of the CURIS® flow Irrigation pump before each use.



Always keep the lock lever of the rotary pump closed during operation – do not open it. Failure to comply can cause injury to operating personnel.



The user must not touch the CURIS® flow Irrigation pump and the patient at the same time.



Serious incidents that occur in relation to the product must be reported to the manufacturer and the responsible public authority in the member state in which the user and/or patient resides.



Portable and mobile HF communication equipment may affect electromedical devices. See the guidelines and manufacturer declaration for electromagnetic compatibility in [Chapter 10.2](#)

The CURIS® flow Irrigation pump has no safety measures against burns with the application of HF surgery devices.

The CURIS® flow Irrigation pump can be used in conjunction with HF surgery devices. However, powerful electromagnetic interference produced in the immediate vicinity of electric motors, high-voltage power lines, PCs, monitors, or other – possible defective – electric appliances may interfere with the functioning of the device in some cases.

Consider such interference if inexplicable phenomena are observed on the device. Proceed as follows to restore the proper functioning of the device:

1. Set up the devices at a safe distance from each other, observe their functionality, and check them for plausibility.
2. Make sure that cables do not touch each other, since electromagnetic coupling may occur during energy input of the HF surgery device.
3. Take all necessary precautions to avoid malfunctions.



NOTE

Observe the instructions and recommendations of the HF surgery device manufacturer

Only approved accessories specified by the manufacturer may be used so that the device is not negatively influenced by electromagnetic phenomena. Furthermore, this ensures that the electromagnetic interference emission is maintained as determined in the type test.

6 Cleaning and disinfection

For cleaning and disinfection, turn the device off, disconnect it from the mains network, and remove connected components and accessories. Liquids must not be allowed to get into the interior of the device when applying cleaning agents and disinfectants.



Submerging or spraying the device can lead to hazards or destroy the irrigation pump.

Use the wiping method for cleaning and disinfection.

Use a cloth moistened with a mild soap solution or 70% isopropanol solution for cleaning. After cleaning, disinfect the surfaces with a pH-neutral, approved disinfectant on a detergent-alcohol basis with up to 70% alcohol. Always follow the instructions of the disinfectant manufacturer for disinfection.

Ensure that cleaning agents and disinfectants are fully removed or evaporated before using the device.

Visual inspection: The sockets of all connections and the plugs of the connecting cables must not be soiled in any way.

7 Error display and troubleshooting



Error

If an error in the self-test sequence or during the operation is detected, the LED status indicator (5) lights up red and the error message “E” is shown on the display. The irrigation pump then stops operating, and operation cannot be resumed.

For troubleshooting see below table or turn off the irrigation pump with the power switch (1) on the front of the device, check all connections, and turn the device back on with the power switch. If the LED status indicator (5) still lights up red, contact your Sutter representative or the manufacturer.

Device fault	Cause	Corrective action
There is no device function and the elements on the front remain off	No power supply	Check the power supply
	Mains cable is not or not correctly inserted into the socket or into the mains cable connection socket (10)	Check the connection of the mains cable
	Device is not switched-on	Switch on the device by using the power switch on the front of the device (1).
	Internal power supply defective	Device is defective, service case. Contact your Sutter representative or the manufacturer
Flow setting control element (3) has no function	Rotary encoder is defective	Replace rotary encoder. Contact your Sutter representative or the manufacturer
Device is switched on, but no irrigation fluid is conveyed	Rotary pump lock lever (8) is open	Close the rotary pump lock lever (8)
	The silicone segment was pinched during insertion into the rotary pump	Open the rotary pump lock lever (8) and make sure the silicone segment is not pinched while closing the lock lever
	The silicone segment was not inserted correctly into the rotary pump (7)	Open the rotary pump lock lever (8) and make sure the silicone segment is inserted according to the flow direction indicator (7)
	A non-compatible bipolar cord and tubing set is used.	Use only from the manufacturer recommended bipolar cord and tubing sets
	Irrigation fluid bag is empty	Replace the irrigation fluid bag
	The selected flow setting is „0“	Increase the flow setting by turning the control element (3) clockwise
	Pause function is activated	Deactivate the pause function with the pause button (6) on the front of the device
Not enough irrigation fluid is conveyed	There is not enough irrigation fluid	Make sure that sufficient irrigation fluid is available, if needed change the irrigation fluid bag
	Selected flow setting is too low	Increase the flow setting by turning the control element (3) clockwise
	Irrigation fluid bag is not connected correctly with the spike of the irrigation tubing	Check that the spike of the irrigation tubing is inserted correctly
	Luer connection is not connected correctly with the instrument	Check that the luer connection of the irrigation tubing is fully inserted

	The silicone segment was pinched during insertion into the rotary pump	Open the rotary pump lock lever (8) and make sure the silicone segment is not pinched while closing the lock lever
	A non-compatible bipolar cord and tubing set is used.	Use only from the manufacturer recommended bipolar cord and tubing sets
	The rollers located in the rotary pump (7) must be replaced	Replace rotary pump rollers. Contact your Sutter representative or the manufacturer
No device function while operating with CURIS® RF Generator	CURIS® RF Generator interconnecting cable is not or not correctly inserted into the connection socket (9)	Check the connection of the CURIS® RF Generator interconnecting cable
	CURIS® RF Generator interconnecting cable is defective	Replace CURIS® RF Generator interconnecting cable. Contact your Sutter representative or the manufacturer
	Internal defect	Device is defective, service case. Contact your Sutter representative or the manufacturer
No device function while operating with CURIS® flow one-pedal footswitch with push-button	CURIS® flow one-pedal footswitch cable is not or not correctly inserted into the connection socket (9)	Check the connection of the CURIS® flow one-pedal footswitch
	CURIS® flow one-pedal footswitch with push-button is defective	Replace CURIS® flow one-pedal footswitch with push-button. Contact your Sutter representative or the manufacturer
	Internal defect	Device is defective, service case. Contact your Sutter representative or the manufacturer
The LED status indicator (5) lights up red and the error message “E” is shown on the display after self-test sequence	Internal defect	Turn the irrigation pump off with the power switch (1) on the front of the device, check all connections, and turn the device back on with the power switch. If the LED status indicator (5) still lights up red, contact your Sutter representative or the manufacturer. Device is defective, service case

The LED status indicator (5) lights up red and the error message “E” is shown on the display during the operation	Internal defect	Turn the irrigation pump off with the power switch (1) on the front of the device, check all connections, and turn the device back on with the power switch. If the LED status indicator (5) still lights up red, contact your Sutter representative or the manufacturer.
---	-----------------	---

7.1 Maintenance and repair

The irrigation pump does not contain any parts that can be maintained or repaired by the user. The product may only be repaired by the manufacturer or persons/organizations authorized by the manufacturer. Otherwise the warranty and any possible additional liability claims against the manufacturer are voided.

Contact your Sutter representative or the manufacturer for repair or replacement.



Warning

Unauthorized changes can cause malfunctions or failure of the irrigation pump.

8 Accessories

Sutter Medizintechnik GmbH recommends the following tested, compatible accessories:

- CURIS® flow one-pedal footswitch with push-button (REF: 360115)

REF: 360115



Product availability depends on regulations in various markets and may vary as a result.



To avoid injury to the patient and/or operating personnel, only use the device with accessories and single-use items for which safe, unproblematic use is confirmed.

If untested accessories of other manufacturers that are not included in the scope of delivery for the device or approved as accessories by the manufacturer and that are connected to the interfaces of the device are to be used, these have to verifiably comply with the corresponding EN specifications (for example, EN 60601 for electromedical devices). Any person who connects additional devices is a system configurator and therefore responsible for compliance with the current version of the system

requirements according to the IEC 60601-1 standard. Using device components that do not correspond to the original version may impair performance, safety, and EMC characteristics.

Maintenance, cleaning, and disinfection of the CURIS® flow one-pedal footswitch with push-button

When these instructions are followed, the footswitch requires minimal maintenance. Depending on the ambient conditions and frequency of use, regular maintenance and the inspection of the housing and connecting cables for damage and problematic dirt is recommended. For exclusively manual cleaning, only use a cloth wetted with water and a mild cleaning agent.

Never use cleaning agents that may attack the plastic surfaces, such as instrument cleaners, scouring cleaning agents, or cleaners containing solvents.

Technical data – CURIS® flow one-pedal footswitch with push-button

Standards	IEC 60601-1 IEC 60529	
Class	Class I according to Regulation 2017/745/EU	
Material	Pedals made of break-proof, self-extinguishing thermoplastic material, cast aluminum housing	
Connecting cable	Permanently connected and sealed control cable	
Protection category	IP X8 (1 m / 35 min) according to IEC 60529	
Switching element	Reed contact	
Switching voltage	Max. 25 V AC / 60 V DC	
Switching current	Max. 1 A	
Breaking capacity	Max. 20 VA	
Service life	>1 million switching cycles	
Approvals	AP compatible	
Environmental conditions for transportation and storage	Ambient temperature	-40 °C to +70 °C
	Relative humidity	10 % to 100 %
	Atmospheric pressure	500 hPa to 1120 hPa
Environmental conditions for operation	Ambient temperature	-10 °C to +60 °C
	Relative humidity	10 % to 100 %
	Atmospheric pressure	800 hPa to 1060 hPa

9 Transportation and packaging

Observing the transportation notes on the packaging and the prescribed environmental conditions for transportation and storage (see [Chapter 10.1](#)) is mandatory for transportation of the device. Failure to comply can result in damage. To avoid damaging the device, transport the product exclusively in the original packaging.

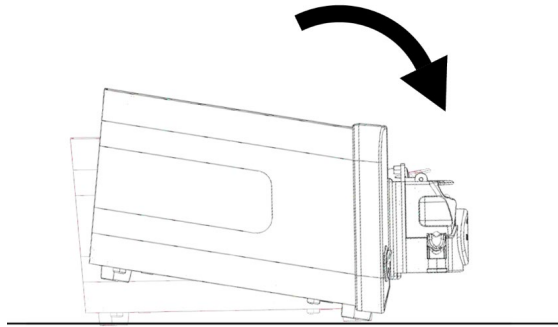

NOTE

When removing the irrigation pump from the packaging, note that the device's center of gravity is at the front.

9.1 Incoming inspection and transport damage

The device and accessories must be inspected for possible transport damage and defects immediately on receipt (see scope of delivery in [Chapter 2](#)).

9.2 Claims for damages

Claims for compensation can only be asserted if the seller and/or shipper is notified promptly. A record of damages must be prepared immediately. The record of damages has to be submitted to the nearest Sutter representative or directly to Sutter so that claims for compensation can be reported to the insurer.

9.3 Returns

Use the original packaging to return a device to Sutter or a Sutter service center. If this is not available, packaging that properly protects the device being returned is mandatory. In case of improper packaging, liability rests exclusively with the sender. The following accompanying documents must be included:

- Name and address of the sender/return recipient
- Model and device number
- Description of the defect and, if applicable, where the defect occurred
- The version of these instructions for use
- A notice that the device has been properly disinfected

9.4 Device disposal

The entire packaging can be returned to the seller and is recycled as far as possible. Otherwise dispose of the packaging as waste paper and/or household garbage.



Identification of electrical and electronic equipment according to Directive 2012/19/EU (WEEE2)

This device contains materials that must be disposed of in accordance with environmental protection requirements. The European Directive 2012/19/EU on waste electrical and electronic equipment (WEEE2) applies to this device. Therefore, this device is marked with the symbol of a crossed-out waste bin on the type plate.

You can return the device to the manufacturer/ Sutter representative. This ensures disposal in accordance with the respective national version of the WEEE directive.

**NOTE**

Disposables used with the device, such as bipolar cord and tubing sets, have to be disposed of according to the clinic's procedures and rules.

10 Technical information

10.1 Technical data, standards, certification

Mains connection	100 - 240 V; 50 / 60 Hz	
Power consumption	Max. 30 VA	
Protection class	I	
Type	CF (Cardiac Floating); defibrillator safe	
Protection level	IP21 (protection against finger contact/foreign objects larger than 12 mm. Protection against vertically dripping water)	
Classification acc. to 2017/745/EU (MDR)	Class I	
Signal level	Approx. 50 dB(A)	
Weight	Approx. 3.0 kg	
Dimensions	W x H x D 230 mm x 125 mm x 250 mm	
Standards	IEC 60601-1: 2005, AMD1:2012, AMD2:2020 IEC 60601-1-2: 2014, AMD1:2022 IEC 60601-1-6: 2010, AMD1:2013, AMD2:2020	
Environmental conditions for transportation and storage	Ambient temperature	- 25 °C to +70 °C
	Relative humidity	5 % to 90 %
	Atmospheric pressure	500 hPa to 1060 hPa
Environmental conditions for operation	Ambient temperature	+10 °C to +40 °C
	Relative humidity	30 % to 75 %
	Atmospheric pressure	700 hPa to 1060 hPa
	Compliant with Regulation 2017/745/EU (MDR)	
Rx ONLY	Sale restricted to attending physicians (USA)	

10.2 Guidelines and manufacturer declaration for electromagnetic compatibility

Appropriate operating environment:

The CURIS® flow Irrigation pump is suitable for operation in the electromagnetic environment in professional healthcare facilities, for example, clinics (emergency rooms, sickrooms, intensive care, operating rooms, outside the HF-shielded room for magnetic resonance imaging, first aid facilities). The customer and/or user of the CURIS® flow Irrigation pump should ensure that it is used in an electromagnetic environment as described below.

The CURIS® flow Irrigation pump is not approved for use in aircraft or the military field. The appropriate EMC requirements for these environments have not been tested.

10.2.1 Electromagnetic emissions

Measurement of emitted interference	Compliance	Electromagnetic environment guidelines
High-frequency emitted interference according to CISPR 11	Group 1	The emission of electromagnetic energy by the CURIS® flow Irrigation pump while fulfilling its intended function is unavoidable. Nearby electronic equipment may be affected.
High-frequency emitted interference according to CISPR 11	Class B	The CURIS® flow Irrigation pump is suitable for use in the specified electromagnetic operating environment.
Emission of harmonics according to IEC 61000-3-2	Class A	
Emission of voltage fluctuations/flicker according to IEC 61000-3-3	Complies	

10.2.2 Electromagnetic interference resistance

Interference resistance tests	Test level according to IEC 60601	Compliance level	Electromagnetic environment – guidelines
Discharge of static electricity (ESD) IEC 61000 4-2	± 8 kV contact discharge ± 2 kV air discharge ± 4 kV air discharge ± 8 kV air discharge ±15 kV air discharge	± 8 kV contact discharge ± 2 kV air discharge ± 4 kV air discharge ± 8 kV air discharge ±15 kV air discharge	Floors should be made of wood or concrete, or surfaced in ceramic tiles. If synthetic floor coverings are installed, the relative humidity must be at least 30%.
Fast transient electrical interference/bursts according to IEC 61000-4-4	±2 kV for mains cables ±1 kV for input and output cables	±2 kV for mains cables ± 1 kV for input and output cables	The quality of the supply voltage should correspond to a normal commercial or hospital environment.
Impulse voltages (surges) IEC 61000 4-5	±1 kV differential mode voltage ±2 kV common mode voltage	±1 kV differential mode voltage ±2 kV Common mode voltage	The quality of the supply voltage should correspond to a typical commercial or hospital environment.
Voltage drops, brief disruptions, and fluctuations in the supply voltage IEC 61000 4 11	< 5% U_T (> 95% drop in U_T) for 1/2 period at 0, 45, 90, 135, 180, 225, 270 and 315 degree	< 5% U_T (> 95% drop in U_T) for 1/2 period at 0, 45, 90, 135, 180, 225, 270 and 315 degree	The quality of the supply voltage should correspond to a normal commercial or hospital environment. If users of the CURIS® flow Irrigation pump require continued function even in case of interruptions in the power supply, we recommend

	<p>0 % U_T (100 % drop in U_T) for 1 period at 0 degree</p> <p>70 % U_T (30 drop in U_T) for 25 periods bei at 0 degree</p> <p>0 % U_T (100 % drop in U_T) for 250/300 periods</p>	<p>0 % U_T (100 % drop in U_T) for 1 period at 0 degree</p> <p>70 % U_T (30 drop in U_T) for 25 periods bei at 0 degree</p> <p>0 % U_T (100 % drop in U_T) for 250/300 periods</p>	<p>connecting the CURIS® flow Irrigation pump to an uninterruptible power supply or a battery.</p>
<p>Magnetic field at supply frequency (50/60 Hz) IEC 61000-4-8</p>	<p>30 A/m</p>	<p>30 A/m</p>	<p>Magnetic fields at the supply frequency should correspond to the typical values found in a commercial or hospital environment.</p>
<p>Close range magnetic field IEC61000-4-39</p>	<p>134,2 kHz 65 A/m Pulse modulation 2,1 kHz</p> <p>13,56 MHz 7,5 A/m Pulse modulation 50 kHz</p>	<p>134,2 kHz 65 A/m Pulse modulation 2,1 kHz</p> <p>13,56 MHz 7,5 A/m Pulse modulation 50 kHz</p>	<p>Field generating devices should maintain a minimum distance of 30 cm (or 12 inches) from the parts and pipeworks of the CURIS® flow irrigation pump, designated by the manufacturer.</p>
<p>Note: U_T is the AC mains voltage prior to application of the test levels.</p>			

The CURIS® flow Irrigation pump complies with following interference test levels according to IEC 60601-1-2 Edition 4 Table 9.

Interference resistance tests	Test level according to IEC 60601	Compliance level	Electromagnetic environment – guidelines
<p>Radiated HF interference according to IEC 61000-4-3</p> <p>In direct vicinity to wireless communication devices</p> <p>Table 9 of IEC 60601-1-2 Ed.4</p>	<p>385 MHz Pulse modulation 18 Hz 27 V/m</p>	<p>385 MHz Pulse modulation 18 Hz 27 V/m</p>	<p>Portable and mobile radio devices should not be used closer to the CURIS® flow Irrigation pump, including the lines, than the recommended separation distance that is calculated according to the equation suitable for the transmission frequency.</p> <p>Recommended separation distance: $d = 1.2\sqrt{P}$ for 80 MHz to 800 MHz $d = 2.3\sqrt{P}$ for 800 MHz to 2.5 GHz Where P is the maximum output power rating of the transmitter in watts (W) according to the transmitter manufacturer and d is the recommended separation distance in meters (m).</p> <p>According to an inspection on site ^{a)}, the field strength of stationary radio transmitters should be less than the compliance level ^{b)} for all frequencies. Interference is possible in the vicinity of devices which carry the following graphic symbols.</p> <div style="text-align: center;">  </div>
	<p>450 MHz FM Modulation ± 5 kHz Hub 1 kHz Sinus 28 V/m</p>	<p>450 MHz FM Modulation ± 5 kHz Hub 1 kHz Sinus 28 V/m</p>	
	<p>710, 745, 780 MHz Pulse modulation 217 Hz 9 V/m</p>	<p>710, 745, 780 MHz Pulse modulation 217 Hz 9 V/m</p>	
	<p>810, 870, 930 MHz Pulse modulation 18 Hz 28 V/m</p>	<p>810, 870, 930 MHz Pulse modulation 18 Hz 28 V/m</p>	
	<p>1720, 1845, 1970 MHz Pulse modulation 217 Hz 28 V/m</p>	<p>1720, 1845, 1970 MHz Pulse modulation 217 Hz 28 V/m</p>	
	<p>2450 Mhz Pulse modulation 217 Hz 28 V/m</p>	<p>2450 Mhz Pulse modulation 217 Hz 28 V/m</p>	
	<p>5240, 5500, 5785 MHz Pulse modulation 217 Hz 9 V/m</p>	<p>5240, 5500, 5785 MHz Pulse modulation 217 Hz 9 V/m</p>	



Portable HF communication devices (radio devices) including their accessories such as antenna cables and external antennas should not be used at a distance of less than 30 cm (12 inches) from the components and lines of the CURIS® flow Irrigation pump designated by the manufacturer. Failure to comply can impair the performance characteristics of the device.



In case of electrostatic air discharges of ± 15 kV it is possible that the display (2) turns off or the pump stops. In these cases, you can restart the device by switching the power switch on the front of the device (1). Switch the unit off and on again to restart the unit. There should be 10 seconds between switching off and switching on again.

Interference resistance tests/standard	Test level according to IEC 60601	Compliance level	Electromagnetic environment/guidelines
Conducted HF interference according to IEC 61000-4-6	$3 V_{\text{eff}}$ 150 kHz to 80 MHz $6 V_{\text{eff}}$ in ISM and amateur radio frequency bands between 150 kHz to 80 MHz 80% AM at 1 kHz	$3 V_{\text{eff}}$ 150 kHz to 80 MHz $6 V_{\text{eff}}$ in ISM and amateur radio frequency bands between 150 kHz to 80 MHz 80% AM at 1 kHz	Portable and mobile radio devices should not be used closer to the CURIS® flow Irrigation pump, including the lines, than the recommended separation distance that is calculated according to the equation suitable for the transmission frequency. Recommended separation distance: $d = 1.2\sqrt{P}$ for 80 MHz to 800 MHz $d = 2.3\sqrt{P}$ for 800 MHz to 2.5 GHz Where P is the maximum output power rating of the transmitter in watts (W) according to the transmitter manufacturer and d is the recommended separation distance in meters (m). According to an inspection on site ^{a)} , the field strength of stationary radio transmitters should be less than the compliance level ^{b)} for all frequencies. Interference is possible in the vicinity of devices which carry the following graphic symbols. 
Radiated HF interference according to IEC 61000-4-3	3 V/m 80 MHz to 2.7 GHz 80 % AM at 1 kHz	3 V/m 80 MHz to 2.7 GHz 80 % AM at 1 kHz	

Notes:

NOTE 1: The higher frequency range applies at 80 MHz and 800 MHz.

NOTE 2: These guidelines may not be applicable in all cases. Electromagnetic propagation is affected by absorption and reflection from structures, objects, and people.

^{a)} The field strength of stationary transmitters such as base stations of mobile telephones and mobile radio devices, amateur radios, AM and FM radio and TV transmitters cannot be theoretically determined precisely in advance. In order to determine the electromagnetic environment with regard to the stationary transmitters, an investigation of the electromagnetic phenomena at the site should be considered. If the measured field strength at the location where the CURIS® flow Irrigation pump is used exceeds the aforementioned compliance levels, the irrigation pump should be monitored to confirm it is functioning as intended. Should unusual performance characteristics be observed, additional measures may be required, such as changing the alignment or location of the CURIS® flow Irrigation pump.

^{b)} The field strength should be less than 3 V/m across the frequency range of 150 kHz to 80 MHz.

Address of the manufacturer

Distributed by:

Manufacturer:

Sutter Medizintechnik GmbH
Alfred-Walz-Str. 22
79312 Emmendingen / Germany



Phone: +49 (0) 7641 96256-0
Fax: +49 (0) 7641 96256-30
E-mail: info@sutter-med.de
www.sutter-med.de

Only for US:

Distributed by:

Sutter Medical Technologies USA
3159 Royal Drive, Suite 340
Alpharetta, GA 30022 - USA

Office phone: +1 678-336-9353
Fax number: +1 470-308-3155
E-mail: info@sutter-usa.com
www.sutter-usa.com

Changes reserved!

REF 899080-EN; 2023-07-25